

"Innovative Irrigation Solutions"

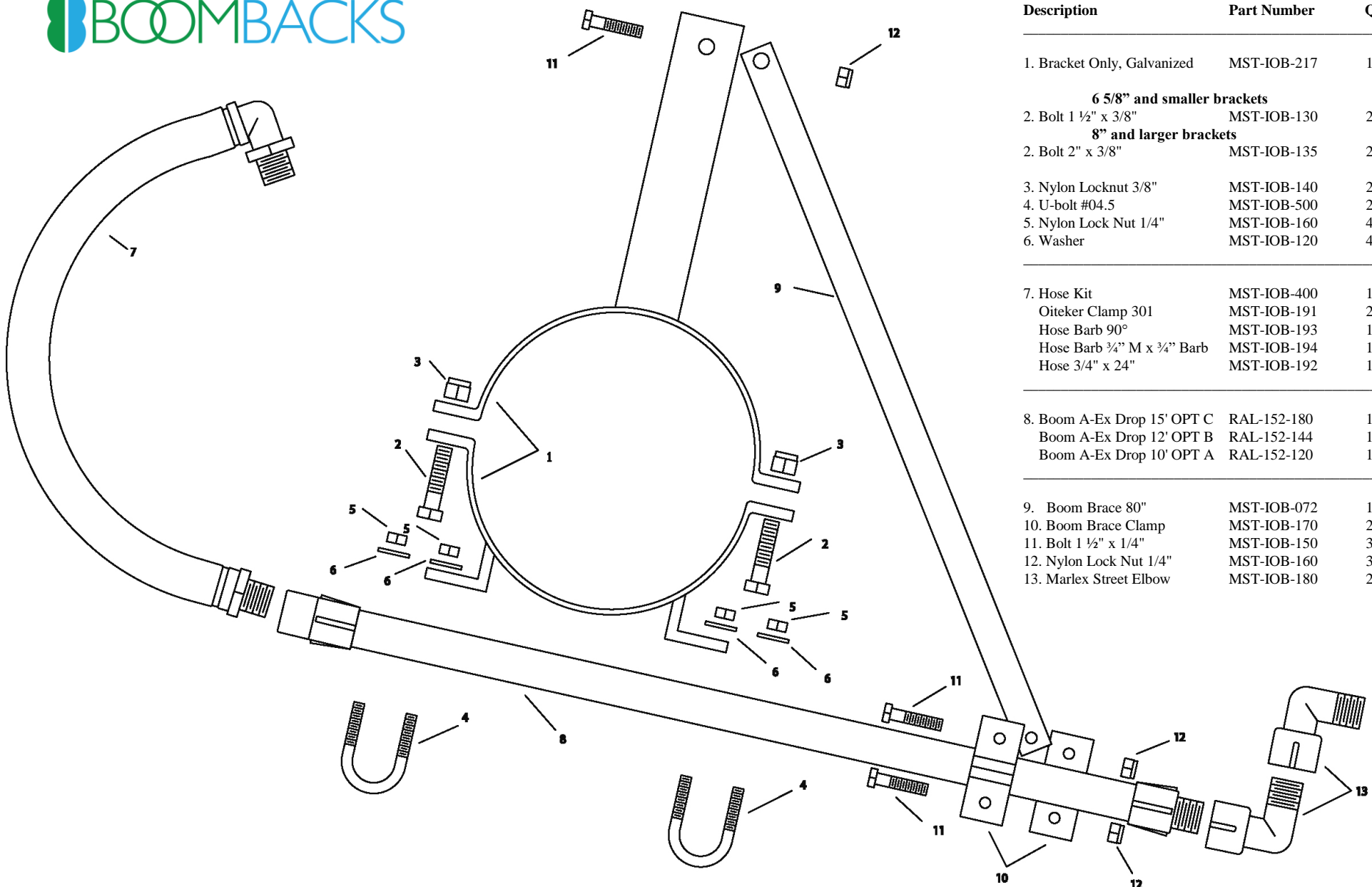

# ALUMI BOOM W/BRACE

10', 12' & 15' OPTION A, B & C



Description	Part Number	Qty.
1. Bracket Only, Galvanized	MST-IOB-217	1
<b>6 5/8" and smaller brackets</b>		
2. Bolt 1 1/2" x 3/8"	MST-IOB-130	2
<b>8" and larger brackets</b>		
2. Bolt 2" x 3/8"	MST-IOB-135	2
3. Nylon Locknut 3/8"	MST-IOB-140	2
4. U-bolt #04.5	MST-IOB-500	2
5. Nylon Lock Nut 1/4"	MST-IOB-160	4
6. Washer	MST-IOB-120	4
<hr/>		
7. Hose Kit	MST-IOB-400	1
Oiteker Clamp 301	MST-IOB-191	2
Hose Barb 90°	MST-IOB-193	1
Hose Barb 3/4" M x 3/4" Barb	MST-IOB-194	1
Hose 3/4" x 24"	MST-IOB-192	1
<hr/>		
8. Boom A-Ex Drop 15' OPT C	RAL-152-180	1
Boom A-Ex Drop 12' OPT B	RAL-152-144	1
Boom A-Ex Drop 10' OPT A	RAL-152-120	1
<hr/>		
9. Boom Brace 80"	MST-IOB-072	1
10. Boom Brace Clamp	MST-IOB-170	2
11. Bolt 1 1/2" x 1/4"	MST-IOB-150	3
12. Nylon Lock Nut 1/4"	MST-IOB-160	3
13. Marlex Street Elbow	MST-IOB-180	2

## IRRIGATION ACCESSORIES COMPANY

Phone (360) 896-9440 P.O. Box 820118 Orchards, WA 98682 Fax (360) 896-9438